

E - THEORY/OPERATION

1990 Nissan 240SX

1990 ENGINE PERFORMANCE
Theory & Operation

Nissan; 240SX

INTRODUCTION

This article covers basic description and operation of engine performance-related systems and components. Read this article before diagnosing vehicles or systems with which you are not completely familiar.

AIR INDUCTION SYSTEM

SWIRL COMBUSTION VALVE (SCV) SYSTEM

NOTE: For location and identification of ECU terminals, see appropriate L - WIRING DIAGRAMS article.

The SCV system is designed to improve engine torque and power production by increasing or decreasing intake manifold induction volume under different driving conditions. A limited induction volume is desirable at low or medium speed under heavy load. This will increase intake velocity and improve atomizing of fuel and combustion efficiency. An increased induction volume is desirable under heavy load and high speed condition.

SCV system consists of swirl control valve (built into intake manifold), diaphragm type swirl control valve actuator and swirl control valve solenoid.

SWIRL CONTROL VALVE

Valve is used to modify the induction passage of the SCV system. It is set in the fully closed or fully open position by the swirl control valve actuator. Valve actuator is regulated by the ECU-controlled swirl control valve solenoid.

SWIRL CONTROL VALVE SOLENOID

Swirl control valve solenoid receives power from a 10-amp fuse in the relay box. Solenoid is energized when ECU provides a ground for solenoid through ECU terminal No. 12. When ECU activates solenoid, manifold vacuum passes through solenoid to swirl control valve actuator, pulling swirl control valve closed.

COMPUTERIZED ENGINE CONTROLS

The Electronic Concentrated Engine Control System (ECCS) is a computerized emission, ignition, and fuel control system. A single Electronic Control Unit (ECU) uses input voltage signals received from various input components to control output. ECU compares each input signal to the appropriate preset parameter preprogrammed in ECU and adjusts output voltage signals accordingly. This allows optimum vehicle performance under various operating conditions.

Voltage to ECU and components requiring battery voltage is supplied by a safety relay and/or a main relay. Safety relay is used to prevent damage to ECU in the event of reverse polarity at the

battery cables. To determine power distribution to ECCS components on specific models, see appropriate WIRING DIAGRAMS article.

ELECTRONIC CONTROL UNIT (ECU)

The ECU consists of a microcomputer, inspection lights, diagnostic mode selector, connectors and wiring for voltage signal input, voltage signal output and power supply. The unit is not serviceable and should not be opened. Inspection lights are provided on side of unit so system operation can be checked. The control unit contains memory and logic circuits, enabling it to interpret sensor inputs and control various engine systems.

ECU LOCATIONS

Application	Location
240SX	Under Right Side of Dash

NOTE: Components are grouped into 2 categories. The first category covers INPUT DEVICES, which control or produce voltage signals monitored by the ECU. The second category covers OUTPUT SIGNALS, which are components controlled by the ECU.

INPUT DEVICES

Vehicles are equipped with different combinations of input devices. Not all devices are used on all models. To determine the input usage on a specific model, see appropriate L - WIRING DIAGRAMS article. The available input signals include are as follows.

A/C SWITCH

Informs ECU when A/C system is on. ECU response by increasing idle speed to improve idling and reduce emissions. During heavy engine load, ECU will also open the A/C clutch relay to disengage A/C clutch.

BATTERY VOLTAGE COMPENSATION

Injector's pulse width is directly affected by battery voltage. As battery voltage drops, so does the injector's pulse width, causing a lean air/fuel mixture. To compensate for this, ECU monitors battery voltage and increases injector's pulse width if voltage drops. This monitored voltage is used with other input values to calculate idle speed and is a factor for determining ignition timing.

COOLANT TEMPERATURE SENSOR

Coolant temperature sensor is installed in the coolant inlet housing or intake manifold coolant passage. Sensor senses changes in temperature by monitoring the resistance of a thermistor. As temperature increases, the resistance decreases.

Sensor sends temperature information to ECU for air/fuel mixture, timing and idle speed control. During warm-up from cold start, ECU increases fuel enrichment to maintain engine performance. As engine temperature increases, the ECU gradually decreases fuel enrichment until engine reaches normal operating temperature.

CRANKSHAFT ANGLE SENSOR

The crankshaft angle sensor monitors engine speed and piston position. The crankshaft angle sensor, which is built into the distributor, has a rotor plate and a wave-forming circuit. The rotor plate has 360 small outer slits (one degree apart) to determine crankshaft angle, and 4 (4-cylinder) or 6 (V6) larger inner signal slits (90 (4-cylinder) or 60 (V6) degrees apart) to determine engine speed. See Fig. 1. The signal slit for the No. 1 cylinder is the largest of the 4 (4-cylinder) or 6 (V6) inner signal slits to allow ECU to determine TDC for No. 1 cylinder.

When the signal rotor plate passes the space between the Light Emitting Diode (LED) and photo diode, the slits in the signal rotor plate alternately cut the light from LED to the photo diode. This causes a pulsating voltage, which is converted into an on-off pulse by the wave-forming circuit and sent to the ECU. ECU uses this signal to control fuel injection, ignition timing and other functions.

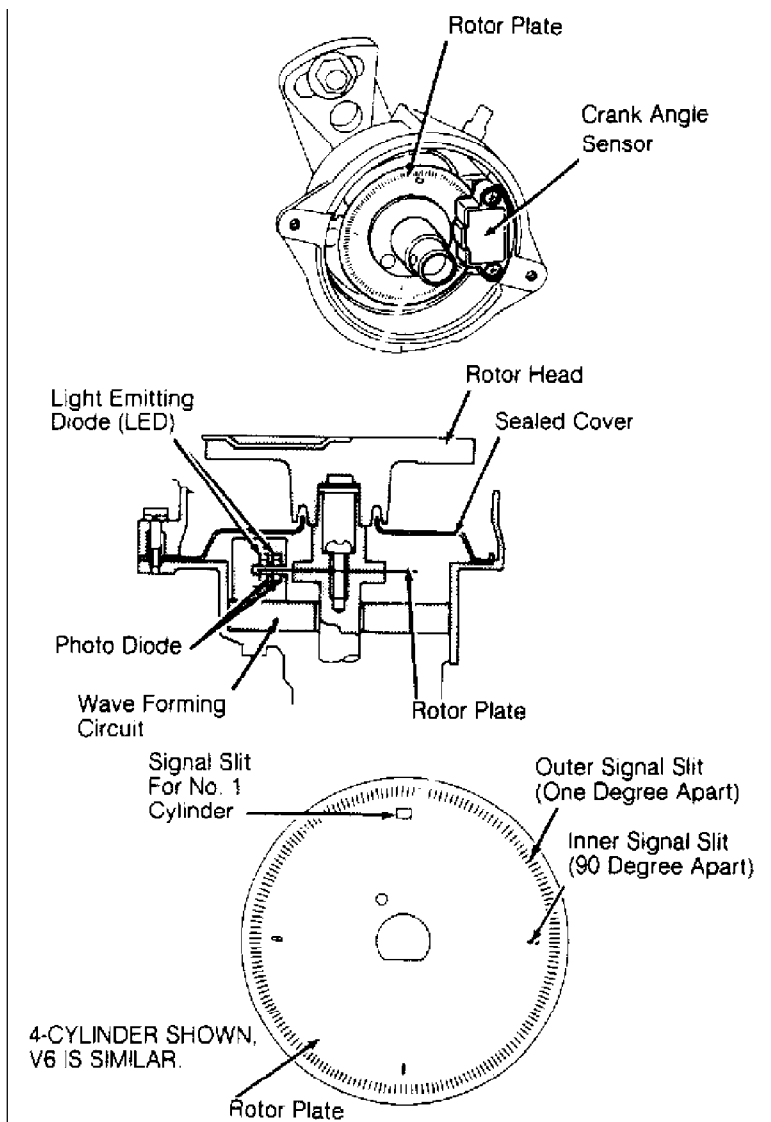

Fig. 1: Distributor/Crank Angle Sensor
 Courtesy of Nissan Motor Co., U.S.A.

EXHAUST GAS (OXYGEN) SENSOR

Sensor monitors the amount of unburned oxygen in the exhaust gases. When heated in the presence of exhaust gases, sensor provides a voltage signal which is used to adjust air/fuel mixture (amount of injection time) to obtain optimum combustion. Two types of oxygen sensor are used. The 4-cylinder models use a Zirconia oxygen sensor which produces a varying voltage signal relative to the oxygen content in the exhaust gases.

EXHAUST GAS TEMPERATURE SENSOR (CALIF MODELS ONLY)

The exhaust gas temperature sensor, located near EGR valve, detects temperature of exhaust gases passing through EGR valve. The sensor has a thermistor which changes its resistance value in response to changes in the exhaust gas temperatures. As the temperature of the exhaust gases increases, the resistance of the sensor decreases. ECU analyzes these changes in resistance and adjusts output voltage signals to EGR solenoid accordingly.

IGNITION SWITCH

Informs ECU when ignition is in ON and START positions. When ECU receives voltage signal for START position, it will actuate injectors, compute and initiate ignition timing sequence and other functions including EGR control override during start-up.

INHIBITOR SWITCH (A/T)

Switch is located on transmission/transaxle. Switch signals ECU of increased engine load when vehicle is in gear. This signal is used to calculate idle speed, ignition timing and injector operation.

MASS AIRFLOW METER

The mass airflow meter uses a hot-wire type sensing element. Incoming air passing through the airflow meter causes the hot wire to cool. As a result, ECU must apply additional current to maintain hot wire at the precalibrated temperature. The ECU measures airflow by monitoring the amount of additional current required to maintain hot wire at the precalibrated temperature. On Sequential Fuel Injection (SFI) models, airflow meter is located in main air intake duct.

If airflow meter output current is outside normal operational range, a malfunction in airflow meter is indicated. ECU will go to throttle position sensor for information on driving condition. During this period, ECU will limit engine speed to less than 2000 or 3000 RPM depending on model. This will inform the driver that the vehicle is driving under fail-safe conditions and needs attention.

Since the hot wire is exposed to atmospheric contaminants, the ECU is programmed to clean the hot-wire each time the ignition switch is cycled off. This is accomplished by heating the hot wire to 1832°F (1000°C) for one second after ignition has been turned off for 5 seconds. This function will not occur if engine speed has not exceeded 1500 RPM, vehicle speed has not exceeded 12 MPH, engine has stalled with ignition on, or engine is hot.

NEUTRAL SWITCH (M/T)

Switch is located on transmission/transaxle. Switch signals ECU of increased load when vehicle is in gear. Information is used to calculate idle speed, ignition timing and injector operation.

POWER STEERING OIL PRESSURE SWITCH

Switch is attached to the power steering high pressure line. Switch monitors the power steering load and sends signal to the ECU. When oil pressure exceeds a predetermined amount, ECU will send a voltage signal to idle speed control valve to increase idle speed.

THROTTLE POSITION SENSOR (TPS) & IDLE SWITCH

The TPS has a potentiometer which varies output voltage in response to changes in throttle position. This information is relayed to the ECU in the form of input voltage signals on the 3-terminal TPS harness. See Fig. 2. The TPS also has the ability to inform the ECU of the rate of changes taking place in throttle plate movement. TPS is attached to throttle body housing and is actuated by movement of the accelerator pedal.

The idle switch is an integral part of the throttle position sensor. Switch is closed at idle and open during all other conditions. Switch is used to inform the ECU when the throttle is closed for fuel-cut on deceleration. Switch has a Wide Open Throttle (WOT) position used only on vehicles equipped with an automatic transmission control unit.

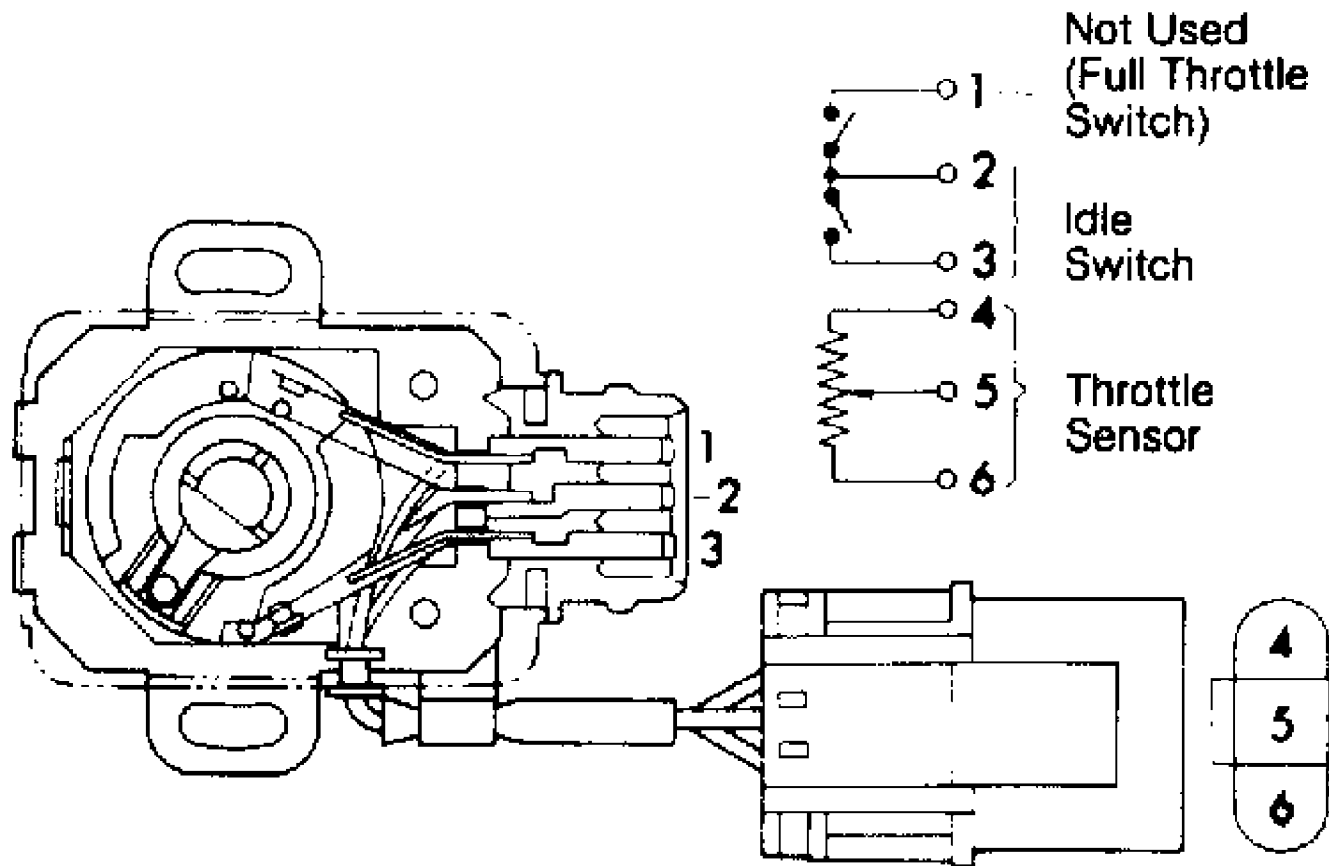

Fig. 2: Throttle Position Sensor & Idle Switch
 Courtesy of Nissan Motor Co., U.S.A.

VEHICLE SPEED SENSOR (VSS)

The VSS provides ECU with vehicle speed signal. VSS consists of a reed switch installed in the speedometer unit. Reed switch transforms vehicle speed into pulse signal.

OUTPUT SIGNALS

NOTE: Vehicles are equipped with different combinations of computer-controlled components. Not all components listed below are used on every vehicle. For theory and operation on each output component, refer to the indicated system under appropriate headings.

A/C CLUTCH

See MISCELLANEOUS CONTROLS.

AIR INJECTION VALVE CONTROL

See EMISSION SYSTEMS.

AIR REGULATOR

See IDLE SPEED under FUEL SYSTEM.

AIRFLOW METER SELF-CLEANING

See MASS AIRFLOW METER under INPUT DEVICES.

AUXILIARY AIR CONTROL (AAC) VALVE

See IDLE SPEED under FUEL SYSTEM.

CANISTER PURGE CONTROL

See EMISSION SYSTEMS.

COOLING FAN MOTOR

See COOLING FAN under MISCELLANEOUS CONTROLS.

EXHAUST GAS RECIRCULATION (EGR) CONTROL

See EMISSION SYSTEMS.

EXHAUST GAS SENSOR

See EXHAUST GAS (OXYGEN) SENSOR under INPUT DEVICES.

FUEL INJECTOR

See FUEL CONTROL under FUEL SYSTEM.

FUEL PRESSURE REGULATOR

See FUEL DELIVERY under FUEL SYSTEM.

FUEL PUMP CONTROL MODULE

See FUEL DELIVERY under FUEL SYSTEM.

IDLE SPEED CONTROL

See IDLE SPEED under FUEL SYSTEM.

POWER TRANSISTOR & IGNITION COIL(S)

See ELECTRONIC IGNITION SYSTEM (DISTRIBUTOR TYPE) under IGNITION SYSTEM.

PRESSURE REGULATOR CONTROL SOLENOID

See FUEL DELIVERY under FUEL SYSTEM.

DUAL LED SELF-DIAGNOSTIC SYSTEM (5 MODES)

See SELF-DIAGNOSTIC SYSTEM.

SWIRL CONTROL VALVE SOLENOID

See SWIRL COMBUSTION VALVE SYSTEM under AIR INDUCTION SYSTEM at beginning of article.

FUEL SYSTEM

NOTE: For location and identification of ECU terminals, see appropriate L - WIRING DIAGRAMS article.

FUEL PUMP

The electric in-tank fuel pump is turned on by the ECU. Depending upon the system in use, either voltage or ground is supplied directly to the fuel pump. Fuel pump is activated when ECU supplies the missing voltage or ground signal through the fuel pump relay. See FUEL PUMP RELAY for appropriate models.

Depending on the system, fuel pump will be energized by the ECU for up to 5 seconds when ignition is first turned on, during cranking and running, and will be de-energized approximately one second after engine stops.

FUEL PUMP RELAY

Fuel pump has its own ground circuit. Fuel pump relay receives current from fused battery voltage or from the ignition switch when switch is in the ON position. Relay is energized by ECU when a ground is supplied at ECU terminal No. 104 (terminal No. 108 on Van). This causes relay contacts to close, delivering battery voltage to the in-tank fuel pump.

FUEL PRESSURE REGULATOR

Fuel is delivered to the injector from the in-tank electric fuel pump. Fuel pressure at the injector is regulated by the fuel pressure regulator located in the fuel return line between the injector and the fuel tank. The pressure regulator is a sealed unit divided into 2 chambers (fuel and spring) by a diaphragm. The fuel chamber receives fuel through the inlet side from the injector fuel rail. The spring chamber is connected to intake manifold vacuum.

A vacuum-operated diaphragm inside the regulator maintains fuel pressure at a specific range, taking into consideration changes in engine load. At idle, intake manifold vacuum is high, causing the diaphragm to be pulled down, allowing excessive fuel to be returned to the fuel tank. As the throttle is depressed, intake manifold vacuum decreases, allowing diaphragm regulator spring to overcome manifold vacuum, causing diaphragm to block fuel returning to fuel tank. This causes an increase in fuel pressure.

PRESSURE REGULATOR CONTROL SOLENOID

When the pressure regulator control solenoid is energized, vacuum to the fuel pressure regulator is blocked, causing fuel pressure increase. ECU energizes the pressure regulator control solenoid for 30 seconds each time the vehicle is started. When coolant temperature is greater than 172°F (78°C) and engine speed is less than 2500 RPM or engine load is light, ECU will energize the pressure regulator control solenoid for up to 3 minutes. This improves hot engine start.

FUEL CONTROL

FEEDBACK SYSTEM

ECU calculates base injection pulse width by processing signals from the crankshaft angle sensor and mass airflow meter. After receiving signals from sensors detecting engine conditions, ECU adds fuel enrichment (preprogrammed into the control unit) to the base injection width to obtain optimum fuel mixture for all operating conditions. Fuel enrichment is always available under the following conditions: during warm-up, starting, off idle, under heavy load and when engine temperature is high.

This fuel injection system incorporates mixture ratio feedback. It is designed to maintain a precise mixture ratio. Through the use of a Zirconia (4-cylinder) exhaust gas sensor located in the exhaust manifold, ECU can adjust air/fuel ratio to optimally control exhaust emissions and engine performance. This function takes place during closed loop operation and continuously monitors itself to stay within an acceptable emissions output range. However, this feedback system can be overridden and will operate in open loop when one or more of the following conditions exist:

- * Starting
- * Engine and/or exhaust sensor cold
- * Driving at high speeds or under heavy load
- * Idling
- * Exhaust gas sensor monitors a too rich condition for over 10 seconds
- * Fuel shutoff solenoid is activated
- * Exhaust gas temperature sensor is malfunctioning or vehicle is decelerating.

FUEL INJECTOR

The fuel injector is a small elaborate solenoid. The ECU sends a duration signal to the injector which in turn opens to high pressure fuel supplied by the fuel pump.

PORT FUEL INJECTION

Port fuel injected vehicle can operate in one of two injection modes, simultaneous or sequential. In simultaneous injection mode, fuel is injected into all 4 or 6 cylinders at the same time. In sequential injection mode, the injectors are triggered in spark plug firing order. Fuel injection will shift from sequential to simultaneous mode under the following conditions: engine speed is less than 300 RPM, engine temperature is less than 140°F (60°C) and during starting.

If airflow meter malfunctions, ECU will enter fail-safe mode. In fail-safe mode, fuel injection are determined from internal default

tables based on throttle position. During fail-safe mode, engine speed is limited to less than 2000 or 3000 RPM depending on model. When the engine reaches this maximum RPM, it will not go faster, indicating the fail-safe system is in effect and vehicle needs servicing.

IDLE SPEED

IDLE SPEED CONTROL

ECU controls engine idle speed according to engine operating conditions and component/model application. ECU will send an on signal to adjust and compensate idle speed under the following conditions (if applicable on system): from starting to 20 seconds after start, low battery voltage, headlights on, heater switch on, A/C switch on, rear defogger on, power steering oil pressure switch on, radiator fan switch on, during deceleration and when vehicle is moving at idle. ECU will also send voltage signal to one or more of the following components; AAC Valve, FICD, Air Regulator

AUXILIARY AIR CONTROL (AAC) VALVE (SOLENOID TYPE)

The ECU processes signals received from sensors to determine the optimum idle speed under varying engine conditions. The ECU senses engine condition and determines the best idle speed with regards to coolant temperature and transmission/transaxle gear position. ECU will then send an electrical on-off signal corresponding to the difference between actual and optimum idle speed. The AAC solenoid then regulates the amount of by-passing air by varying the electrical signal's on time.

AUXILIARY AIR CONTROL (AAC) VALVE (MOTOR TYPE)

The ECU processes signals received from sensors to determine the optimum idle speed for various engine conditions. The AAC valve is a stepper motor with 4 windings. Windings are energized to extend or retract AAC plunger to increase or decrease air by-passed around throttle plate. When plunger retracts, idle increases. When plunger extends, idle speed decreases. AAC valve is mounted on idle air adjusting unit. See Fig. 3.

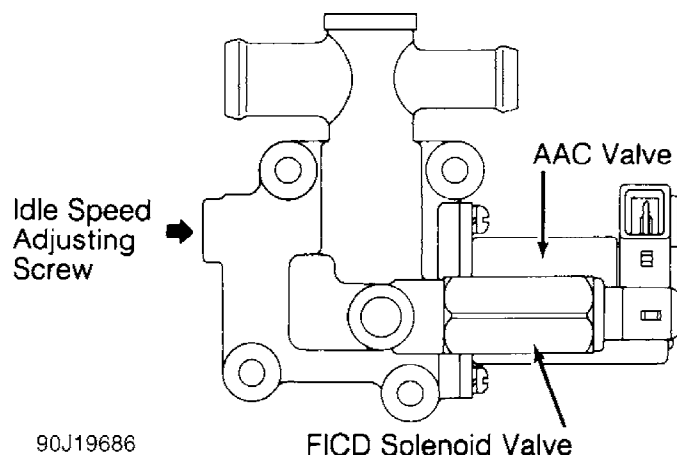

90J19686
Fig. 3: Idle Air Adjusting Unit (Access Shown, Others Similar)
Courtesy of Nissan Motor Co., U.S.A.

AIR-CUT VALVE

The air-cut valve is mounted under the Auxiliary Air Control (AAC) valve. Air-cut valve sensing unit is exposed to coolant flow. As coolant temperature gradually increases, the air-cut door will begin closing to limit maximum airflow through AAC, eliminating possible dieseling in the event of AAC failure.

AIR REGULATOR

The air regulator provides an air by-pass when engine is cold for fast idle during warm-up. A bimetallic heater and rotary shutter valve control the rate of air by-passing. See Fig. 4. When the bimetallic heater and shutter are cold, air by-pass port is open. As engine starts and an electrical current is permitted to flow through the bimetallic heater, it warms up and closes the air by-pass port. The air regulator and fuel pump are both energized by the fuel pump relay.

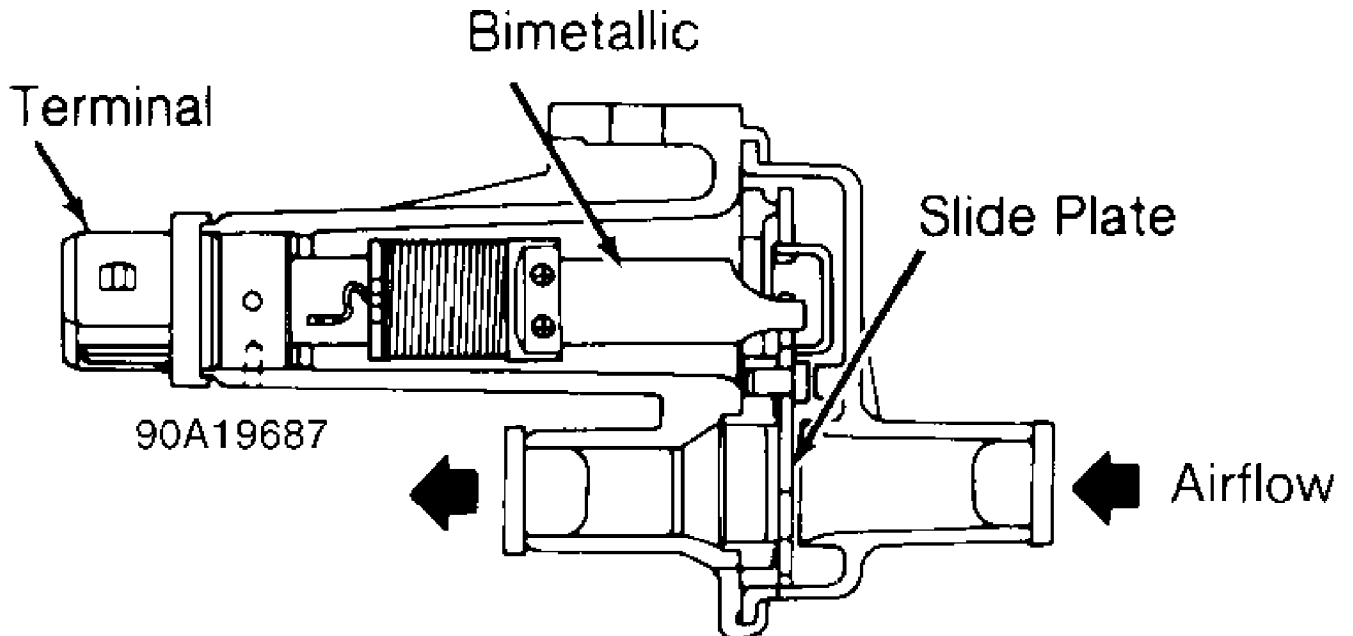

Fig. 4: Air Regulator (Pathfinder, Pickup, 240SX & 300ZX)
Courtesy of Nissan Motor Co., U.S.A.

IDLE-UP SOLENOID

Idle-up solenoid is attached to the throttle body. It supplements by-pass air to increase idle speed whenever auxiliary air control or fast idle control device is not able to maintain idle speed due to excessive engine load.

FAST IDLE CONTROL DEVICE (FICD) SOLENOID

FICD increases idle speed for a few seconds when vehicle is first started and when the A/C compressor is engaged.

IGNITION SYSTEM

NOTE: All models use a Light Emitting Diode (LED) crank angle sensor. For additional information on operation see INPUT DEVICES.

ELECTRONIC IGNITION SYSTEM (DISTRIBUTOR TYPE)

A crank angle sensor mounted inside the distributor monitors engine speed and piston location. See Fig. 5. Signals created by the crank angle sensor are sent to the Electronic Control Unit (ECU).

POWER TRANSISTOR & IGNITION COIL(S)

Power Transistor uses ignition signals received from ECU to trigger ignition coil. Two ignition coils and power transistors are used on the dual spark plug system (Van). Power for ignition coil(s) is supplied through the ignition switch.

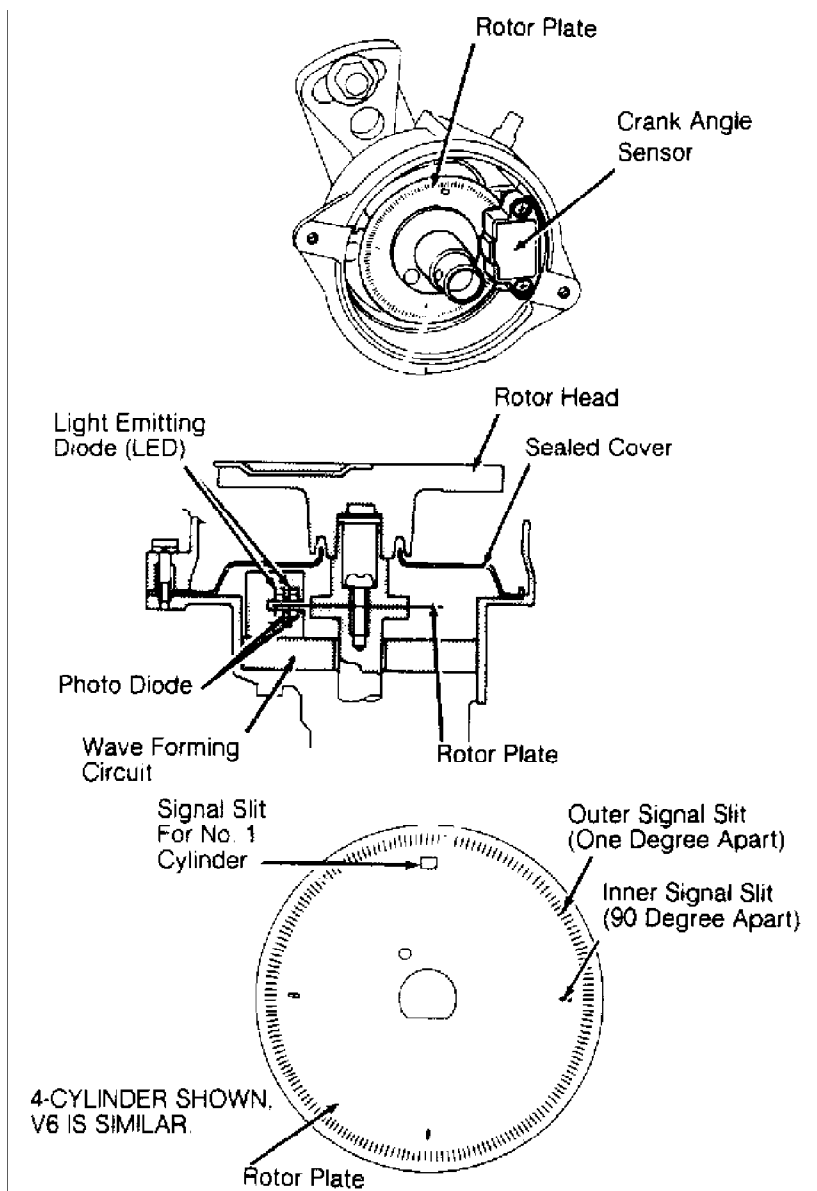

Fig. 5: Distributor/Crank Angle Sensor
Courtesy of Nissan Motor Co., U.S.A.

IGNITION TIMING CONTROL SYSTEM

The ignition system controls ignition timing very precisely by matching vehicle operating conditions to preprogrammed timing advance and retard specifications. These parameters are stored in the Electronic Control Unit (ECU) memory. The computer uses input from the crank angle sensor, coolant and various other sensors to determine advance requirements.

IGNITION TIMING CONTROL

Ignition timing is controlled by the ECU according to engine operating conditions. Optimum ignition timing for various driving conditions is preprogrammed and stored in the ECU. ECU receives and processes electrical signals from various sensors to determine present driving conditions. ECU will then select the optimum timing signal for the present driving conditions and send voltage signal to the power transistor to control timing advance and detonation retard operation (if equipped).

EMISSION SYSTEMS

AIR INJECTION VALVE (AIV) CONTROL

The air injection system is designed to send air to exhaust manifold to reduce exhaust emissions of hydrocarbons (HC) and carbon monoxide (CO). The system consists of an AIV and AIV control solenoid. The AIV is designed for one-way use and consists of a one-way reed valve and lock-out diaphragm. AIV control solenoid will be activated by ECU when vehicle is in the following conditions:

- * Idling or running at temperatures between 59°F (15°C)-140°F (60°C)
- * Idling at temperatures greater than 158°F (70°C)
- * Decelerating.

When negative exhaust system pressure is present, one-way reed valve will open, and if AIV control solenoid is activated, air will be drawn into exhaust manifold. This allows for continued burning of HC and CO in the exhaust and 3-way catalytic converter.

AUTOMATIC TEMPERATURE CONTROL (ATC) AIR CLEANER

The ATC is located in the air cleaner assembly. ATC maintains air temperature entering throttle body at a constant range. This provides a leaner air/fuel mixture to reduce exhaust emissions. ATC air cleaner also improves engine warm-up characteristics and helps prevent throttle body icing.

The ATC air cleaner assembly consists of an air cleaner housing, vacuum motor, temperature sensor, air control valve, hot air duct, fresh air duct and various connecting hoses.

FUEL EVAPORATION SYSTEM

The fuel evaporation system is used to reduce emissions of hydrocarbons (HC) into the atmosphere. The system consists of a sealed fuel tank, vacuum relief filler cap, charcoal canister, purge control valve, fuel-check valve, canister purge and vacuum signal lines, and vapor vent lines.

Fuel vapor from the sealed fuel tank is stored in the activated charcoal canister when the engine is not running. Fuel vapor is retained in the canister until purged by air drawn through the bottom of the canister to the intake manifold during engine operation.

When engine is running at idle, purge control valve is closed

and only a small amount of stored vapor flows into the intake manifold through the constant purge orifice. As the engine speed increases and the throttle vacuum rises higher, the purge control valve opens and vapors are drawn into the intake manifold through the main purge orifice and the constant purge orifice. See Fig. 6.

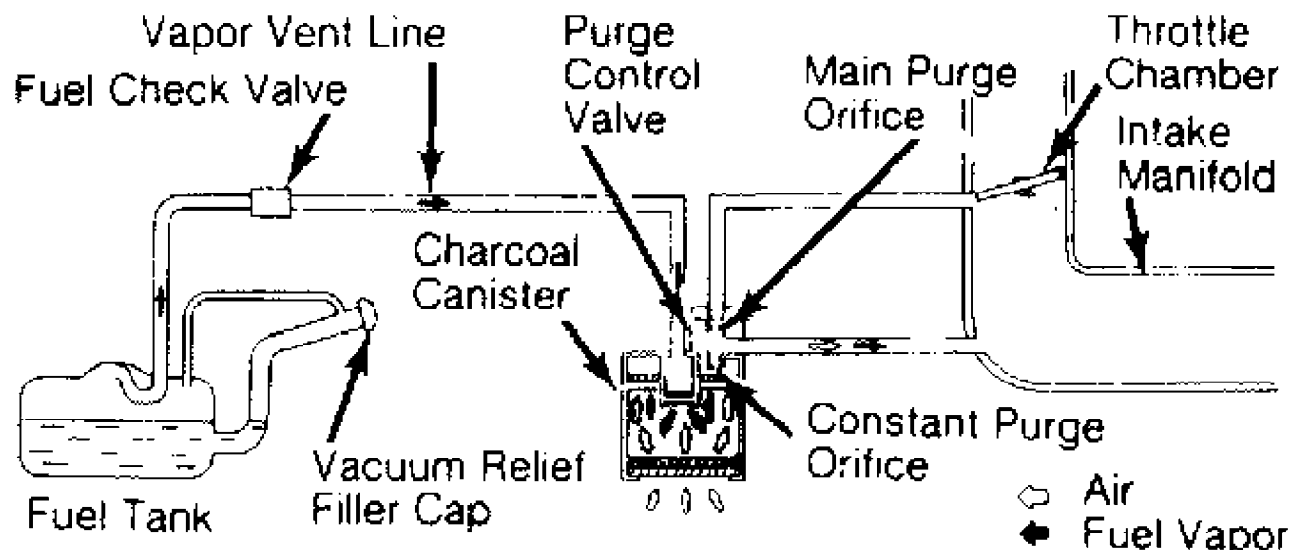

Fig. 6: Fuel Evaporation System
 Courtesy of Nissan Motor Co., U.S.A.

EXHAUST GAS RECIRCULATION (EGR) CONTROL

To reduce exhaust gas emissions of NO_x (oxides of nitrogen), an exhaust gas recirculation system is incorporated within the Electronic Concentrated Engine Control System (ECCS). To reduce NO_x emissions, a portion of exhaust gases from the exhaust manifold is returned to the intake manifold, and then to the combustion chamber to be reburned. This is controlled by the EGR valve, EGR control solenoid valve and backpressure transducer (some models). EGR system does not operate under some or all of the following conditions:

- * Engine starting
- * Throttle valve switch on
- * Under heavy load
- * Low engine temperature
- * High engine temperature at high engine speeds.

Under these conditions, ECU energizes the coil within the control solenoid to pull the plunger downward, allowing control vacuum to bleed off to atmosphere. California models are also equipped with exhaust gas temperature sensor located near the EGR valve. This sensor is used to determine when EGR is actually effective. If sensor indicates a low exhaust gas temperature when EGR action is commanded, ECU can determine if an EGR fault is present.

EGR BACKPRESSURE TRANSDUCER

A backpressure transducer is installed in the EGR valve vacuum hose. During periods of low exhaust backpressure, when EGR is not desirable, the transducer allows EGR vacuum signal to bleed off to atmosphere. When backpressure increases, internal diaphragm of transducer is lifted to block off vacuum bleed, allowing vacuum to react on EGR diaphragm.

SELF-DIAGNOSTIC SYSTEM

NOTE: For additional information and operating procedures on the self-diagnostic system, see G - TESTS W/CODES article.

A dual LED self-diagnostic system located on the ECU, is used. The ECU is located under the right side of the dash.

SELF-DIAGNOSTIC SYSTEM

Application	CHECK ENGINE LIGHT	LED COLORS (No.)
240SX	Calif.	Red & Green (2)

SELF-DIAGNOSTICS DUAL LED SYSTEM (5 MODES)

The self-diagnostic system is capable of detecting ECCS malfunctions and storing trouble codes. Since even intermittent codes are stored, all codes are available for interpretation unless codes have been cleared or ignition has been cycled on-off 50 times since the malfunction last occurred.

Self-diagnostic system will be operated in one of 5 modes. Modes are manually changed using screwdriver through access port on ECU (toggling selector slide switch from OFF to ON position on Pathfinder and Pickup). To enter or change mode, turn screwdriver fully clockwise (selector slide switch in ON position). Inspection lights will begin to flash. When desired mode has been entered, turn screwdriver fully counterclockwise (selector slide switch to OFF position). Red LED and Green LED perform different functions in different modes.

MODE I

This is the normal vehicle operating mode. Green LED will indicate loop status. If Green LED is not blinking, vehicle is in open loop or there is a fault with the oxygen sensor or sensor circuit. If Green LED is blinking, vehicle is in closed loop. If a malfunction occurs, Red LED and CHECK ENGINE light (if equipped) will illuminate, indicating an ECCS malfunction has occurred.

MODE II

Both Red LED and Green LED are used to monitor air/fuel mixture feedback control. Green LED will function as described in MODE I. If vehicle is in open loop, the Red LED and Green LED will remain on or off. So in order for results to be valid, vehicle must be in closed loop. In closed loop, Red LED remains off if system is running rich, comes on if system is running lean and blinks synchronously with Green LED if system is at the ideal air/fuel ratio.

MODE III

When mode is accessed, codes stored in ECU memory will be flashed by the Green LED and Red LED on the side of the ECU. Green LED will flash code for the 10's-column digit, while Red LED will flash code for one's-column digit. For example: 3 flashes of the Green LED followed by 5 flashes of the Red LED would indicate a code 35.

MODE IV

This mode is used for checking ECCS switch status. When the idle switch, starter switch or vehicle speed sensor are activated, the Red LED will come on and go off as the status changes.

MODE V

This mode represents a real-time diagnostic test of the crank angle sensor, ignition signal, airflow output signal and fuel pump. This mode is accessed for an in-bay running test of the vehicle. The Red LED must be monitored carefully during this test, paying special attention to the number of flashes before each pause. The malfunction code will be displayed only once and will not be stored in memory. If Red LED blinks on and off uniformly, a fault in the crank angle sensor is indicated. If the Red LED flashes twice before a pause, it indicates a fault in the airflow meter. If the Red LED blinks 3 times before a pause, fault in the fuel pump circuit is indicated. If the Red LED blinks 4 times before a pause, a fault in the ignition signal is indicated.

CHECK ENGINE LIGHT (CALF MODELS)

California vehicles are equipped with a CHECK ENGINE light on the instrument panel. Light comes on as a bulb check when the ignition switch is turned to the ON position. Light also comes on when systems related to the emission controls are malfunctioning during normal vehicle operation (MODE 1). For additional information, see G - TESTS W/CODES article.

MISCELLANEOUS CONTROLS

NOTE: Although not considered true engine performance-related systems, some controlled devices may affect driveability if they malfunction.

A/C CLUTCH

If A/C switch is turned on while engine is at idle, ECU will signal the Auxiliary Air Control (AAC) and/or the Idle-Up solenoid to increase idle speed.

During hard acceleration, ECU cuts off the A/C power relay circuit to disengage A/C clutch for several seconds to aid acceleration.

COOLING FAN MOTOR

Cooling fan motor is controlled (through the cooling fan relay) by a thermostatic switch located in the coolant inlet. Failure of any component can cause overheating, dieseling and engine run-on.

TRANSMISSION CONTROLS

Nissan models are equipped with an electronic automatic transmission/transaxle control unit (ATCU) and/or a Shift Lock Control Unit (SLCU).

AUTOMATIC TRANSMISSION/TRANSAXLE CONTROL UNIT (ATCU)

ATCU receives input signals from the ignition coil (RPM

signal), idle switch (on-off signal), throttle sensor (variable signal) and full throttle switch (on-off signal). Based on these values, the ATCU calculates optimum timing and duration to energize shift solenoids, overrun clutch solenoid and lock-up solenoid. ATCU also indicates when overdrive is engaged (if equipped) by illuminating the OD indicator light.

SHIFT LOCK CONTROL UNIT (SLCU)

SLCU receives input signals from the key switch, ignition switch (ON or START position) and the shift lever detent switch. Based on these signals, the SLCU controls the operation of the key lock solenoid (to prevent ignition key from being turned on while vehicle is in gear) or shift lock solenoid (to prevent vehicle from being shifted out of PARK while ignition is off).